

No. 633,548.

Patented Sept. 19, 1899.

O. C. FENLASON.
SCORING TOOL FOR VENEER LATHES.

(Application filed Aug. 30, 1898.)

(No Model.)

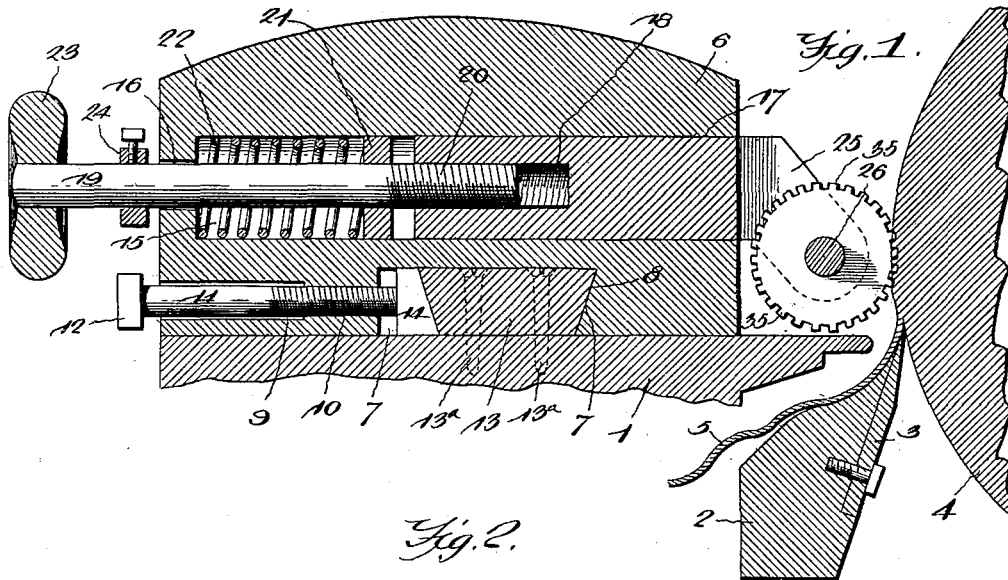

Fig. 1.

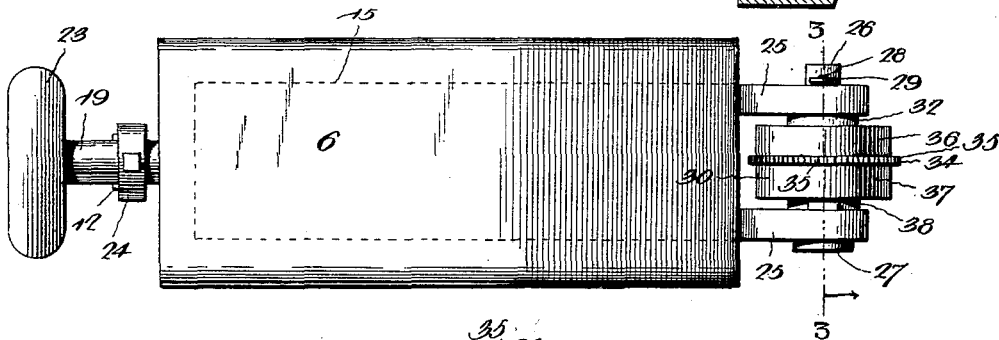
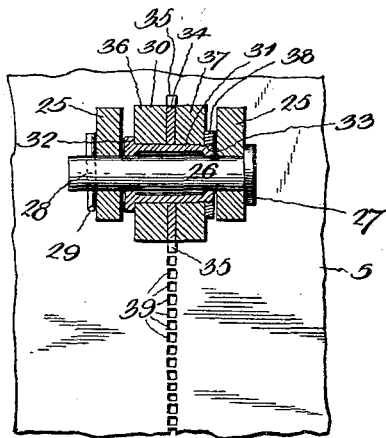

Fig. 2.



Witnesses

J. Graup Kulverwell,
H. A. Barendse

Orin C. Fenlason, Inventor.

By His Attorneys.

C. A. Knowlton

UNITED STATES PATENT OFFICE.

ORIN C. FENLASON, OF HOQUIAM, WASHINGTON.

SCORING-TOOL FOR VENEER-LATHES.

SPECIFICATION forming part of Letters Patent No. 633,548, dated September 19, 1899.

Application filed August 30, 1898. Serial No. 689,825. (No model.)

To all whom it may concern:

Be it known that I, ORIN C. FENLASON, a citizen of the United States, residing at Hoquiam, in the county of Chehalis and State of Washington, have invented a new and useful Scoring-Tool for Veneer-Lathes, of which the following is a specification.

In the art of cutting veneers from a log of wood it is customary to score the veneer for the purpose of facilitating bending the veneer to the required shape in the manufacture of articles of different kinds. So far as I am aware scoring of the veneer has been effected by the employment of a tool on the tool-bar or presser-bar of a veneer-lathe, which scoring-tool is adjusted to have a sharpened edge cut about one-half the way through the wood of the log just prior to the severance of the veneer therefrom. This method of scoring veneers is open to objection for several reasons. First, in scoring thin stock—say from sixteen to thirty to the inch—it is hardly possible to prevent the tool from cutting clear through the veneer or else the tool does not cut deep enough; secondly, a veneer cut only part way through by the sharp tool can be bent only in one direction, which necessitates sorting over of the stock to assemble the veneers, so that the score-marks shall be on the outside thereof and the veneer placed in a position to be bent away from the score-marks, because the veneer would break if bent in the other direction, and, thirdly, the tool requires constant attention to keep it in the proper position and a sharpened condition for service.

It is my object to provide a scoring-tool which will overcome these objections and enable veneers to be produced which can be bent equally as well in one direction as in the other and also to obviate any tendency of the scoring-tool to cut clear through the veneer, so as to effect material economy in the stock.

A further object of the invention is to provide means for accurately adjusting the presentation of the scoring-tool to the work; also, to provide means for regulating the pressure of the tool upon the work, and to provide means for quickly and securely clamping the tool-stock in place on the presser-bar of the veneer-lathe.

With these ends in view my invention consists of a peculiar construction of the scoring-

tool; also, of means for adjusting the tool accurately to the work; also, in means for holding the tool under spring-pressure to the work, and in the peculiar construction of a rotatable scoring-tool head; and the invention finally consists in the novel combination of devices and in the construction and arrangement of parts, which will be hereinafter fully described and claimed.

To enable others to understand the invention, I have illustrated the preferred embodiment of the same in the accompanying drawings, forming a part of this specification, and in which—

Figure 1 is a sectional elevation of a veneer-scoring tool applied in operative relation to a part of a veneer-cutting lathe. Fig. 2 is a plan view of the scoring-tool represented by Fig. 1. Fig. 3 is a transverse sectional view through the rotatable scoring-head on the plane indicated by the dotted line 3 3 of Fig. 2 and showing the tool in relation to a veneer which is scored in accordance with my invention.

Like numerals of reference denote like and corresponding parts in each of the several figures of the drawings.

In order that others skilled in the art may understand the construction and mode of operation of my veneer-scoring tool, I have shown the same applied in proper working position to the log on a part of an ordinary veneer-cutting lathe, and by reference to Fig. 1 it will be seen that the presser-bar of the lathe is indicated by the numeral 1, the knife-rest at 2, a knife or blade 3 clamped to the knife-bar, and 4 is the log from which a veneer 5 is adapted to be cut by the knife 3 on the rotation of the log. It will be understood that no novelty for these devices is claimed herein, because they are ordinary in the art, and the present invention resides in the improved scoring-tool.

All of the operating parts of the scoring-tool are carried by the tool frame or stock 6. (Shown more clearly by Fig. 1.) This frame or stock is preferably cast in a single piece of metal, although this is not material. In the lower face of the tool stock or frame is provided a transverse slot 7, which opens through the lower side of the stock and which has the face 8 inclined or beveled at an an-

gle to the plane of the lower face of said stock. In the horizontal plane of the slot 7 in the tool-stock is formed a horizontal opening 9, the inner portion of which is formed with a female screw-thread 10, which opens into one side of the slot 7. A clamping-bolt 11 passes through the horizontal opening 9 to have its threaded portion engage with the threads 10 of said opening, and the protruding end of this clamping-bolt 11 is provided with an enlarged head 12, by which the bolt may be conveniently rotated to move it into or out of engagement with clamping devices by which the tool-stock is held rigidly in place on the presser-bar 1 of the veneer-lathe.

13 designates a fixed clamping-bar, which is rigidly secured to the lathe presser-bar 1 by means of the transverse screws 13^a, and the edges of this fixed clamp-bar are beveled so as to impart to the bar 13 a dovetailed form in cross-section. The tool-stock 6 is fitted to the presser-bar 1 to rest thereon and receive in its slot 7 the clamping-bar 13, one edge of which fits snugly against the beveled face or end 8 of the slot in the tool-stock. Against the opposite edge of the fixed clamp-bar 13 is fitted a movable clamp or gib 14, which is inserted in the slot 7 and is interposed between the inner end of the clamp-bolt 11 and the fixed clamp-bar 13, whereby the bolt 11 is adapted to be turned to force the movable clamp or gib 14 against the clamp-bar 13, and thus firmly secure the tool-stock in an immovable position on the presser-bar of the lathe.

The tool stock or frame 6 is furthermore provided on a plane above the slot 7 and opening 9 therein with a longitudinal opening or passage 15, which extends nearly through said stock or frame, one end of the opening or passage extending through the face of the stock or frame adjacent to the work; but the opposite end of said opening or passage 15 does not extend through the remote or distal end of the stock 6. In this closed side or end of the stock is provided an opening 16, which is of less diameter than the passage 15, and said opening 16 accommodates an adjusting-spindle by which the scoring-tool head may be accurately regulated with reference to the work, as will presently appear.

17 designates a carrying-stem for the scoring-tool, and this stem in cross-section conforms to the shape and area of the opening or passage 15, so that the stem 17 is adapted to play freely in the tool-stock. At its inner end the tool-carrying stem is provided with an axial female-threaded socket 18, in which is screwed the threaded inner extremity of an adjusting-spindle 19, the threaded part of the spindle, which screws into the tool-carrying stem, being indicated by the numeral 20 in Fig. 1. This adjusting-spindle passes loosely through the opening 16 of the tool-stock, and the protruding end of this spindle 19 is equipped with a hand-wheel 23 or any other

suitable device by which the spindle may be rotated for the purpose of regulating the projection of the tool-carrying stem beyond the stock. This spindle 19 is provided at a point adjacent to its threaded extremity 20 with a fixed collar 21, which constitutes a seat for one end of a coiled spring 22. This spring is housed or contained in the inner part of the passage 15, and it is fitted loosely around the spindle 19, one end of the spring bearing against the collar 21 on the spindle, but its other end finds a seat against the solid part or end of the tool-stock, in which the opening 16 is formed. This spring acts against the spindle, which is rigidly joined to the tool-carrying stem, and the spring is thus adapted to project the stem 17 and the tool carried thereby more or less beyond the face of the tool-stock. The projection of the carrying-stem and the pressure of the spring thereon are regulated by adjustment of the spindle 19, and to prevent the stem and spindle from being projected too far beyond the tool-stock under the pressure of the spring a stop-collar 24 is rigidly secured in a suitable way to the protruding part of the adjusting-spindle 19 and is adapted to abut against the rear end of the tool-stock. The end of the carrying-stem which protrudes beyond the front end of the tool-stock is bifurcated or forked to provide the parallel jaws 25, which sustain a rotatable scoring-tool head, and these jaws 25 are preferably inclined to the longitudinal axis of the carrying-stem and provided with suitable openings, which constitute bearings for an arbor or shaft on which the rotatable head is mounted loosely to turn freely thereon. In the openings or bearings of the jaws 25 is fitted an arbor or shaft 26, which lies transversely to the axis of the carrying-stem 17, and one end of this arbor 26 is formed with a head 27, while its other end has an opening 28 to receive a spring key or cotter 29. The head of the arbor bears against one of the jaws 25, while the key engages with the other jaw, and said arbor is thus confined or held removably in the forked end of the carrying-spindle, so that it may be withdrawn when it is desired to remove the rotatable tool-head.

One of the important features of my invention resides in the construction of a scoring-disk which forms an integral part of a rotatable head 30. This head 30 consists of a sleeve 31, which is formed at one end with a flange or head 32; but its other end is externally threaded, as at 33. The scoring-disk 34 is fitted on the sleeve 31, and it is clamped or held securely in place by the clamping-disks 36 and 37 and the clamping-nut 38. In assembling the parts of the head 30 together the disk 36 is first slipped on the sleeve 31 to abut against the head 32 thereof, the scoring-disk 34 is slipped on the sleeve 31 to abut against the disk 36, the disk 37 is then fitted on the sleeve to abut against the scoring-disk 34, and the nut 38 is screwed on the threaded

end 33 of the sleeve. This nut is tightened against the disk 37 to force the scoring-disk 34 against the disk 36, which in turn is pressed against the head 32 of the sleeve, whereby all the parts are bound firmly together on the sleeve and the scoring-disk is immovably clamped between the disks 36 37. The scoring-head is thus assembled complete ready for insertion into the forked end of the carrying-stem 17, and the sleeve 31 of said head is adjusted in alinement with the openings or bearings in the jaws 25. The arbor 26 is now slipped through the sleeve and the jaws to have its headed end bear against the jaw on one side of the stem, while its perforated end 28 receives the key 29. The rotatable head fits snugly between the jaws to be held in position, thereby providing against any tendency to move endwise on the arbor, and said head is free to rotate on the arbor in the operation of the tool against the work.

The peculiarity in my scoring-tool resides in the formation of the scoring-disk 34 with a series of spaced teeth or points 35, which extend radially from the circumferential edge of the disk and protrude beyond the annular faces of the clamping-disks 36 37. The cutting edge of the scoring-disk 34 is not continuous, but it is interrupted or broken at intervals by the spaces between the points or teeth, and the tool is thus adapted to score the work by a continuous series of pricks or punctures 39, which are spaced apart by non-perforated integral portions of the veneer. This action of the interrupted or broken scoring and working edge of the toothed disk 34 on the work is very advantageous, because there is no possibility of the tool cutting by a continuous line and severing the veneer into sections or parts. One advantage of the rotatable head, constructed as described, resides in the employment of the clamping-disks beyond which the teeth or points 35 of the disk 34 protrude, and said clamping-disks ride directly against the round surface of the log, thus requiring quite a strong pressure of the spring 22 to force the teeth of the disk 34 into the log up to a depth for the disks to ride on the log. This is very advantageous because it obviates frequent adjustment of the presser-bar 1.

In operation the parts of the scoring device are properly assembled together and the stock 6 is clamped on the presser-bar of the veneer-lathe. The adjusting-spindle 19 having been properly adjusted to regulate the projection of the carrying-stem beyond the front end of the tool-stock, the teeth of the rotatable cutter-head are properly presented to the log 4, from which the veneer 5 is to be cut. As the log is rotated and the veneer cut therefrom the scoring-head is pressed by the spring acting on the spindle and stem against the log, so as to puncture and score the same prior to the severance of the veneer by the knife, and as the log rotates and the rotatable head is pressed against the log the

head is rotated by the engagement of the points or teeth with the log. The adjusting-spindle can be turned to regulate the position of the rotatable head to the work, and thus accurately control the presentation of the rotatable head in accordance with the thickness of the veneer which is to be cut from the log.

It is evident that the stock may be readily removed from the presser-bar of the lathe, and that it can be clamped removably in place thereon.

I am aware that changes in the form and proportion of parts and in the details of construction may be made by a skilled mechanic without departing from the spirit or sacrificing the advantages of the invention, and I therefore reserve the right to make such modifications as clearly fall within the scope of the invention.

In the practical service of the scoring attachment very little attention is required to keep the rotatable head adjusted in proper relation to the work, because the teeth or spurs punch or prick through the wood into the timber before the veneer is cut from the log. The teeth of the scoring-disk require no sharpening, because they work to a sharp edge by use.

In my implement it is not necessary to frequently adjust the presser-bar in order to bring the scoring-tool up to the log. The cutting edge of the knife 3 is on a plane parallel with the center of the spindles that revolve the log. Hence the thickness of the presser-bar is above the line of the spindles and the tool is on the top of the bar. Now when a log is first placed in the lathe and the tool is adjusted to its surface the tool, as the log is cut away by the knife 3 feeding in toward the center of the log, would have a tendency to gradually disengage as the diameter of the log is decreased unless the presser-bar is moved toward the log; but according to my invention the spring 22 forces the spindle forward to keep the disks 36 37 at all times against the log, and the pressure of the spring is sufficient to force the teeth of the disk through the veneer.

Having thus described the invention, what I claim is—

1. In a scoring attachment for veneer-cutting lathes, the combination with a clamping-bar, of a stock clamped thereto, a carrier movable within the stock, means for positively limiting and adjusting the extent of slidable movement of the carrier within the stock, a pressure-spring acting against the carrier, and a revoluble scoring-head journaled in the carrier and having an unbroken series of puncturing-teeth which protrude from the cylindrical surface of the head, substantially as described.

2. In a scoring attachment for veneer-lathes, the combination with a tool stock or frame of a slidable carrier fitted to said stock, a rotatable scoring-head journaled in the car-

rier and provided with an unbroken series of spaced puncturing-teeth, an adjusting-spindle having threaded connection with the carrier and slidably fitted in the tool stock or 5 frame, and a pressure-spring acting against the spindle to hold the carrier and head in yieldable engagement with the work, substantially as described.

3. In a scoring attachment for veneer- 10 lathes, the combination with a tool stock or frame, of a reciprocating carrier slidably fitted to the stock, an adjusting-spindle adjustably connected to the carrier and fitted loosely to the stock, a pressure-spring acting against 15 the spindle, means for limiting the slidable movement of the spindle and the carrier, and a rotatable scoring-head having an unbroken circular series of teeth and journaled in the carrier, substantially as described.

20 4. In a scoring attachment for veneer-lathes, a disk provided with an unbroken series of integral puncturing-teeth, in combination with a fixed stock, and a yieldable support having said disk mounted revolubly 25 therein for presentation to the work, substantially as described.

5. In a scoring attachment for veneer-lathes, a flat disk provided with integral puncturing-teeth arranged in an unbroken 30 series radially to the axis of the disk, in combination with a fixed stock, a yieldable support in which the disk is revolubly mounted, and means for adjusting the support relative to the stock, substantially as described.

35 6. In a scoring attachment for veneer-lathes, a sectional cylindrical head, and a disk clamped between the members of said head and provided with integral puncturing-teeth arranged in an unbroken series and 40 projecting beyond the surface of said head, combined with a fixed stock, and a yieldable support movably fitted in said stock and having the head journaled therein for rotary motion, said support presenting the head and 45 disk in operative relation to the work, substantially as described.

7. In a scoring attachment for veneer-lathes, the combination with a stock, of a carrier fitted slidably to said stock and having at one end a threaded socket and at its 50 other protruding end the jaws, a revoluble head journaled in the jaws of the carrier and having the disk with the puncturing-teeth, a spindle screwed in the socket of the carrier, and a spring acting against the spin- 55 dle, substantially as described.

8. In a scoring attachment for veneer-lathes, a stock provided in its lower side with a transverse slot having a beveled face and also provided with a longitudinal passage 60 above said transverse slot, and a clamping-bolt fitted in the stock in the horizontal plane of the transverse slot therein, combined with a dovetailed lathe-rail fitted in the slot of said stock to engage the beveled face thereof, 65 a beveled key interposed between the rail and the bolt, a carrier fitted in the upper passage of the stock to play freely therein independently of the clamping devices, and a scoring-tool mounted in the carrier, sub- 70 stantially as described.

9. In a scoring attachment for veneer-lathes, the combination with a lathe-rail, of a stock clamped to said rail and having a 75 longitudinal passage, a carrier slidably fitted in the passage of the stock to play therein independently of the clamping devices for said stock, a revoluble head journaled on a protruding head of the carrier, an adjusting- 80 stem having a threaded engagement with said carrier, a spring acting against the stem to hold the carrier and the head in yieldable relation to the work, and means for limiting the movement of the stem and carrier in one 85 direction, substantially as described.

In testimony that I claim the foregoing as my own I have hereto affixed my signature in the presence of two witnesses.

ORIN C. FENLASON.

Witnesses:

E. W. KARR,
G. H. CARLSON.